

## Standard Equipment/Optional Equipment

### Standard Equipment

Linde twin drive pedals to control forward/reverse travel and braking  
 Original Linde Load Control integrated in armrest  
 Hydraulic suspended seat with extensive range of adjustment  
 Hydrostatic power steering  
 Three wheel configuration with original Linde center-pivot axle for excellent manoeuvrability  
 Linde compact drive axle with maintenance free oil-bath disc brake  
 Famous Linde dual motor drive with 2 x 4,6 kW for 48 V models and 2 x 3,5 kW for the 24 V models  
 11 kW (48 V) maintenance free AC lift motor, 10 kW for 24 V models  
 Curve Assist for automatic, proportional speed adaption  
 Plenty of storage space for writing utensils, beverage cans ...  
 Anti-glare display with clock, hour meter, service information and accurate battery condition indicator  
 Standard truck fits into ISO container  
 Superelastic tyres

Battery capacity for low version (h6 = 1970 mm):  
 E16P = 48 V/575 Ah, E20PL = 48 V/690 Ah  
 Battery capacity for high version with increased battery capacity (h6 = 2130 mm):  
 E16PH = 48 V/700 Ah, E18PH = 48 V/700 Ah  
 E20PH = 48 V/700 Ah, E20PHL = 48 V/840 Ah

**New STANDARD features for the EVO models:**  
 New seat/armrest generation for outstanding ergonomics  
 Improved energy consumption  
 Enhanced tractive force and climbing ability  
 Self-activating parking brake  
 Individual drive dynamic mode providing perfect combination of performance and efficiency  
 Showing battery operating time by the minute  
 Dust and dirt protected Linde Load Control  
 Enlarged step-in for high models  
 New diagnostic plug for fast service access  
 Sensitive traction control for Linde dual motor drive

### Optional Equipment

Single drive pedal with direction selector on armrest  
 Overhead guard can be upgraded to full cabin with roof, front-, rear screens and doors (also available with tinted glass)  
 Wiper-washers for front, rear and roof screens  
 Further seats with additional comfort and adjustments  
 Cab heater with integrated pollen filter  
 Radio with speakers  
 Sun screen, clipboard and interior light  
 Standard mast lifts up to 5650 mm  
 Duplex mast (full free lift) lifts up to 4145 mm  
 Triplex mast (full free lift) lifts up to 6075 mm  
 Single or double additional hydraulics for all mast types  
 Tilt cylinder- and roof protection  
 Integrated sideshift  
 Integrated fork positioner  
 Mirrors

Linde original Blue Spot  
 Road traffic specification  
 Load backrest  
 Swivel seat  
 12 V socket  
 Truck lighting, working lamps  
 Cold store protection  
 Custom paintwork  
 Linde Fleet Management (LFM)  
 Active ventilation while charging

#### Linde energy management

Customized horizontal and vertical battery change incl. NEW hydraulic battery shift  
 Built-in high frequency onboard charger for convenience and flexibility  
 Recirculation of electrolyte

Other options available on request



## Electric Counterbalanced Trucks Capacity 1600 - 2000 kg

E16 *EVO*®, E18 *EVO*®, E20 *EVO*® Series 386\_02



### Safety

The protective overhead guard forms a strong and completely enclosed protective zone providing optimum structural integrity, safety and protection for the operator. The top mounted tilt cylinders provide seamless, smooth control of the tilt movements for excellent load stability in all operating conditions. This unique design also enables slimmer mast profiles to be fitted for outstanding visibility.

### Performance

One would expect a high performance truck to have a high performance traction system – and that is exactly what the Linde compact drive axle and lift system delivers. Powerful motors and intelligent electronic control form an impressive power pack to deliver the highest levels of productivity.

### Comfort

Consistently high levels of performance and efficiency for extended periods are only possible if the operator feels comfortable. The ergonomic layout of all the controls, the adjustability the armrest and seat, Linde Load Control, and twin accelerator pedals provide the best possible intuitive interface between the truck and the operator.

## Features

#### Linde clearview mast design

- With top mounted tilt cylinders for seamless load control and stability
- Excellent view of load and surroundings through the robust yet slim mast profiles
- Nominal capacity retained to maximum lift heights
- High residual capacities in all applications
- Exceptionally stable

#### Linde hydrostatic power steering

- Minimal physical demands on the operator
- Compact ergonomically designed steering wheel
- Linde close coupled steer axle for outstanding manoeuvrability
- Less tyre stress



#### Linde twin accelerator control

- Seamless, rapid reversing without repositioning the feet
- Short pedal travel
- Fatigue-free working
- Increased throughput and performance

#### Linde Load Control

- Small tactile joystick integrated in an adjustable armrest
- Precise and effortless fingertip joystick control of all mast functions
- Safe and highly efficient load handling

#### Linde Dual Motor Drive

- Two powerful AC drive motors
- Seamless acceleration and variable torque characteristics
- Power moduls in DCB-technology for high performance and efficiency cooling



#### Linde operator's compartment

- Ergonomically designed for efficient, fatigue-free working
- Spacious operator's compartment with generous floor plate area
- Cushioned comfort – mast and drive axle are isolated from the chassis and cab by a unique resilient suspension system that absorbs shock loadings



#### Linde compact drive axle

- Twin drive design with high performance Linde AC technology
- Integrated AC lift motor
- Optimum energy efficiency
- Maintenance-free oil-bath disc brake
- Efficient power moduls housed in sealed unit for complete protection
- Short, energy saving power connections



#### Linde energy management

- Optimised energy consumption
- Accurate battery condition indicator
- Simple horizontal or vertical battery changing options
- Optional built-in high frequency charger for convenience and flexibility
- Record of battery usage



# Technical Data according to VDI 2198

		LINDE	LINDE	LINDE	LINDE	LINDE	LINDE		
Characteristics	1.1	Manufacturer							
	1.2	Model designation	<b>E16P (575Ah)</b>	<b>E16PH (700Ah)</b>	<b>E18PH (700Ah)</b>	<b>E20PL (690Ah)</b>	<b>E20PH (700Ah)</b>	<b>E20PHL (840Ah)</b>	
	1.2a	Series	386-02	386-02	386-02	386-02	386-02	386-02	
	1.3	Power unit	Battery	Battery	Battery	Battery	Battery	Battery	
	1.4	Operation	Seat	Seat	Seat	Seat	Seat	Seat	
	1.5	Load capacity	Q (t)	1.6	1.6	1.8	2.0	2.0	2.0
	1.6	Load centre	c (mm)	500	500	500	500	500	500
	1.8	Axle centre to fork face	x (mm)	365	365	370	374	374	374
	1.9	Wheelbase	y (mm)	1429 <sup>1)</sup>	1481 <sup>1)</sup>	1481 <sup>1)</sup>	1537 <sup>1)</sup>	1481 <sup>1)</sup>	1589 <sup>1)</sup>
Weights	2.1	Service weight	(kg)	3015 <sup>2)</sup>	3360 <sup>2)</sup>	3385 <sup>2)</sup>	3360 <sup>2)</sup>	3520 <sup>2)</sup>	3600 <sup>2)</sup>
	2.2	Axle load with load, front/rear	(kg)	4094 / 521	4205 / 755	4562 / 623	4787 / 573	4885 / 635	4905 / 695
	2.3	Axle load without load, front/rear	(kg)	1525 / 1490 <sup>2)</sup>	1670 / 1690 <sup>2)</sup>	1705 / 1680 <sup>2)</sup>	1650 / 1710 <sup>2)</sup>	1705 / 1815 <sup>2)</sup>	1805 / 1795 <sup>2)</sup>
Wheels/Tyres	3.1	Tyres rubber, SE, pneumatic, polyurethane		SE	SE	SE	SE	SE	SE
	3.2	Tyre size, front		180/70-8 (18x7-8)	180/70-8 (18x7-8)	200/50-10-SC15	200/50-10-SC15	200/50-10-SC15	200/50-10-SC15
	3.3	Tyre size, rear		16x6-8-SC15	16x6-8-SC15	16x6-8-SC15	16x6-8-SC15	16x6-8-SC15	16x6-8-SC15
	3.5	Wheels, number front/rear (x = driven)		2x / 2	2x / 2	2x / 2	2x / 2	2x / 2	2x / 2
	3.6	Track width, front	b10 (mm)	930	930	965	965	965	965
	3.7	Track width, rear	b11 (mm)	807	807	807	807	807	807
	Dimensions	4.1	Mast/fork carriage tilt, forward/backward	a/b (°)	5.0 / 7.0	5.0 / 7.0	5.0 / 7.0	5.0 / 7.0	5.0 / 7.0
4.2		Height of mast, lowered	h1 (mm)	2194	2194	2194	2194	2194	2194
4.3		Free lift	h2 (mm)	150	150	150	150	150	150
4.4		Lift	h3 (mm)	2800	3150	3150	2800	3150	3150
4.5		Height of mast, extended	h4 (mm)	3401	3751	3751	3401	3751	3751
4.7		Height of overhead guard (cabin)	h6 (mm)	1970	2130	2130	1970	2130	2130
4.8		Height of seat/stand on platform	h7 (mm)	908	1065	1065	908	1065	1065
4.12		Towing coupling height	h10 (mm)	538	602	602	538	602	602
4.19		Overall length	l1 (mm)	2929	2978	2983	3045	2987	3095
4.20		Length to fork face	l2 (mm)	2029	2078	2083	2145	2087	2195
4.21		Overall width	b1/b2 (mm)	1090 / 1050	1090 / 1050	1172 / 1050	1172 / 1050	1172 / 1050	1172 / 1050
4.22		Fork dimensions	s/e/l (mm)	40 x 80 x 900	40 x 80 x 900	45 x 100 x 900	45 x 100 x 900	45 x 100 x 900	45 x 100 x 900
4.23		Fork carriage to ISO 2328, class/type A, B		2A	2A	2A	2A	2A	2A
4.24		Width of fork carriage	b3 (mm)	980	980	980	980	980	980
4.31		Ground clearance, below mast	m1 (mm)	97	97	97	97	97	97
4.32		Ground clearance, centre of wheelbase	m2 (mm)	103	103	103	103	103	103
4.33	Aisle width with pallet 1000 x 1200 across forks	Ast (mm)	3355 <sup>3)</sup>	3404 <sup>3)</sup>	3409 <sup>3)</sup>	3470 <sup>3)</sup>	3412 <sup>3)</sup>	3520 <sup>3)</sup>	
4.34	Aisle width with pallet 800 x 1200 along forks	Ast (mm)	3479 <sup>3)</sup>	3528 <sup>3)</sup>	3533 <sup>3)</sup>	3595 <sup>3)</sup>	3537 <sup>3)</sup>	3645 <sup>3)</sup>	
4.35	Turning radius	Wa (mm)	1664	1713	1713	1771	1713	1821	
4.36	Minimum pivoting point distance	b13 (mm)	0	0	0	0	0	0	
Performance	5.1	Travel speed, with/without load	(km/h)	20 / 20	20 / 20	20 / 20	20 / 20	20 / 20	20 / 20
	5.2	Lifting speed, with/without load	(m/s)	0.5 / 0.6	0.5 / 0.6	0.5 / 0.6	0.5 / 0.6	0.5 / 0.6	0.5 / 0.6
	5.3	Lowering speed, with/without load	(m/s)	0.58 / 0.5	0.58 / 0.5	0.58 / 0.5	0.58 / 0.5	0.58 / 0.5	0.58 / 0.5
	5.5	Tractive force, with/without load	(N)	2300 / 2300	2300 / 2300	2300 / 2300	2300 / 2300	2300 / 2300	2300 / 2300
	5.6	Maximum tractive force, with/without load	(N)	11000 / 11000	11000 / 11000	11000 / 11000	11000 / 11000	11000 / 11000	11000 / 11000
	5.7	Climbing ability, with/without load	(%)	6.8 / 10.4	6.6 / 9.9	6.1 / 9.4	5.8 / 9.2	5.7 / 8.9	5.7 / 8.9
	5.8	Maximum climbing ability, with/without load	(%)	25.0 / 40.1	23.2 / 35.4	22.2 / 35.1	21.4 / 35.4	20.7 / 33.6	20.4 / 32.8
	5.9	Acceleration time, with/without load	(s)	4.5 / 4.0	4.5 / 4.0	4.5 / 4.0	4.6 / 4.0	4.6 / 4.0	4.7 / 4.1
	5.10	Service brake		hydr./mech.	hydr./mech.	hydr./mech.	hydr./mech.	hydr./mech.	hydr./mech.
	Drive	6.1	Drive motor, 60 minute rating	(kW)	2x 5	2x 5	2x 5	2x 5	2x 5
6.2		Lift motor, rating at S3 15%	(kW)	11	11	11	11	11	11
6.3		Battery according to DIN 43531/35/36 A,B,C,no		43 531 / A	43 531 / A	43 531 / A	43 531 / A	43 531 / A	43 531 / A
6.4		Battery voltage/rated capacity (5h)	(V/Ah)	48 / 550 (575) <sup>4)</sup>	48 / 700	48 / 700	48 / 660 (690) <sup>4)</sup>	48 / 700	48 / 840 (840) <sup>4)</sup>
6.5		Battery weight (± 5%)	(kg)	856	1118	1118	1013	1118	1309
6.6		Power consumption according to VDI cycle	(kWh/h)	5.9	6.1	6.4	6.6	6.6	6.9
Others	8.1	Type of drive control		Digital/stepless	Digital/stepless	Digital/stepless	Digital/stepless	Digital/stepless	Digital/stepless
	8.2	Operating pressure for attachments	(bar)	170	170	170	170	170	170
	8.3	Oil flow for attachments	(l/min)	32	32	32	32	32	32
	8.4	Noise level at operator's ear	(dB(A))	< 65	< 65	< 65	< 65	< 65	< 65

1) Mast in vertical position  
2) Figures with battery, see line 6.4/6.5.  
3) Including a 200 mm (min.) operating aisle clearance.

4) Values in parenthesis in accordance to ZVEI-bulletin „Battery cells application of the euro-series in DIN batteries (issue date July 2002)“

## Lifting capacity diagrams

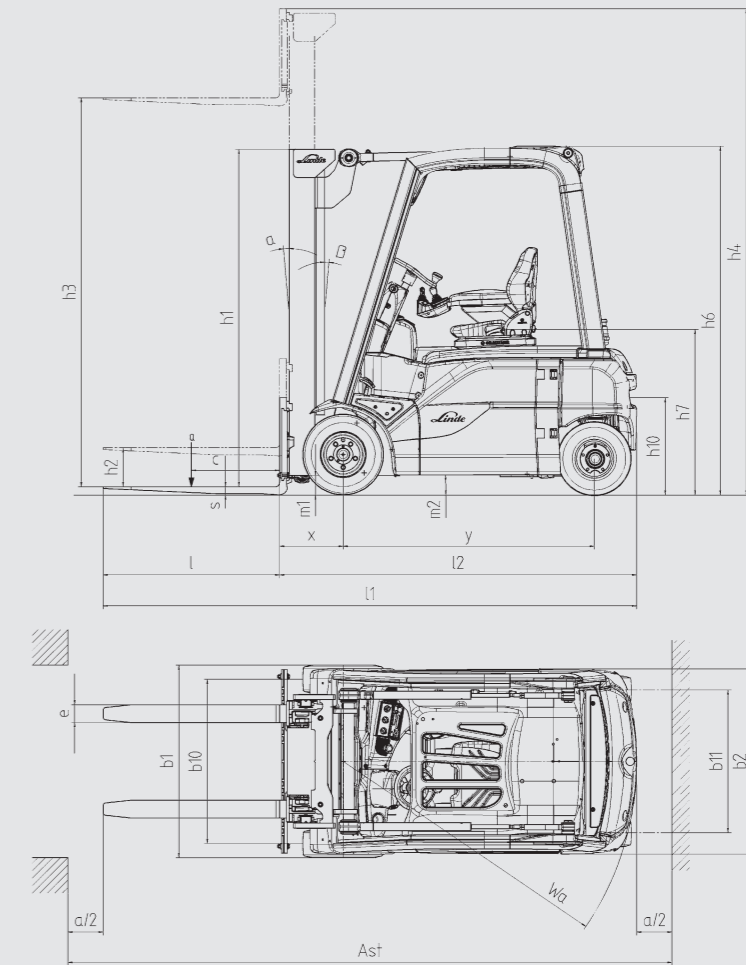
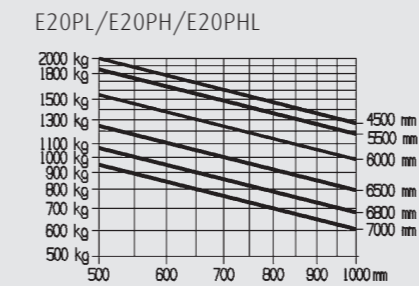
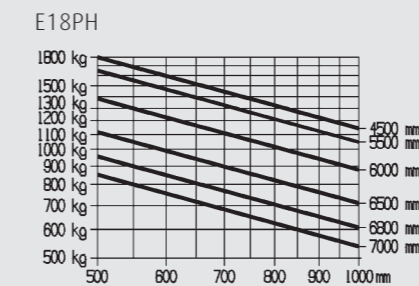
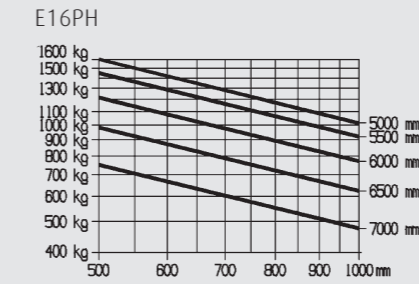
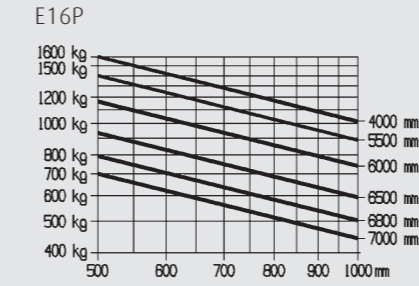

Standard mast (in mm)	E16P/E20PL			E16PH/E18PH/E20PH/E20PHL			
Lift	<b>h3</b>	2800	3150	4250	-	3150	4250
Overall height, retracted (to 150mm free lift)	<b>h1</b>	2021	2196	2746	-	2196	2746
Overall height extended	<b>h4</b>	3363	3713	4813	-	3713	4813
Duplex mast (in mm)	E16P/E20PL			E16PH/E18PH/E20PH/E20PHL			
Lift	<b>h3</b>	2795	3145	3845	-	3145	3845
Overall height, retracted	<b>h1</b>	1946	2121	2471	-	2121	2471
Overall height, extended	<b>h4</b>	3377	3727	4427	-	3727	4427
Special free lift	<b>h2</b>	1343	1518	1868	-	1518	1868
Triplex mast (in mm)	E16P/E20PL			E16PH/E18PH/E20PH/E20PHL			
Lift	<b>h3</b>	4100	4625	5475	-	4625	5475
Overall height, retracted	<b>h1</b>	1946	2121	2471	-	2121	2471
Overall height, extended	<b>h4</b>	4702	5227	6077	-	5227	6077
Special free lift	<b>h2</b>	1344	1519	1781	-	1519	1781

Other lift heights on request  
Minimum lift height does not apply to tall vehicle