



## Standard Equipment/Optional Equipment

### Standard Equipment

#### General:

Overall width (reach legs) 1270 mm/1140 mm (N-version)  
 Linde Load Control for lift/lower, reach, tilt and side shift  
 Linde twin accelerator pedals  
 Comprehensive digital instrument display  
 Sealed, maintenance-free AC 6,5 kW drive & 14 kW lift motors  
 Linde rheological 180° electric steering with tactile feedback  
 Linde Digital Control System (LDC) for smooth, precise electronic control of all traction and hydraulic functions  
 Polyurethane drive and load wheels tyres

#### New Standard Features:

Variable energy saving/performance modes (Economy, Efficiency, Performance) for individual applications  
 Resiliently mounted operator's compartment  
 Fully adjustable air suspension seat with auto adjustment for operator's weight  
 Integral, adjustable control console  
 Generous storage compartments  
 Lift height indicator above free lift zone  
 Key switch, or alternatively PIN code access

#### Mast:

Torsion-resistant fixed clear view triplex mast  
 Tilting fork carriage and integral side shift  
 Fork length 1150 mm

#### Safety:

Monitoring system stops truck in the event of traction, steering or lift failure  
 Seat-actuated traction interlock  
 Linde Curve Assist  
 Four independent braking systems (Regenerative and counter current braking, holding brake control with automatic parking brake and all-wheel brake system)  
 Automatic slowdown at end of reach travel and at max. lift  
 Lift height related travel speed reduction  
 Emergency isolator  
 Battery lock with creep speed interlock  
 Electrical and hydraulic overload protection  
 Protective polycarbonate screen between console and mast  
 Electric horn

### Optional Equipment

Fixed clear view triplex masts with lift heights from 4355 mm to 12955 mm  
 Side shift centering  
 Horizontal fork leveling  
 Soft landing of forks  
 Alternative fork lengths  
 Fork extensions  
 Load backrest  
 Single axis joysticks for each hydraulic function  
 Single accelerator pedal, automotive layout with left foot interlock  
 360° steering (single accelerator pedal only)  
 Reverse steering  
 Lift height pre-selector  
 PVC covered seat  
 Leather reinforced seat squab  
 Heated seat  
 Cold store protection to - 30°C  
 Cold store cab (not available with narrow chassis)  
 Ambient cab (not available with narrow chassis)  
 High Vision armoured glass roof  
 Draught protection door  
 Protection frame  
 Steel mesh profile or polycarbonate insert for overhead guard

Profiled overhead guard for drive-in racking  
 Side guidance wheels  
 Load wheel protection  
 Advanced colour TFT display \*  
 Mast mounted CCTV camera system  
 Vision system, combined cameras on overhead guard and mast, split screen image \*  
 Fan underneath overhead guard for driver comfort  
 Radio Data Terminal bracket  
 Option bar  
 Interior light  
 Auxiliary 12 V power socket  
 LED working lamps  
 Rotating/flashing beacon  
 Blue Spot™ safety light  
 LFM Linde Fleet management  
 Audible traction alarm  
 Additional hydraulic circuit for attachments  
 Battery on rollers  
 Battery roller stand  
 Alternative colour schemes

Other options available on request  
 \* Availability to be advised



Electric Reach Trucks  
 Capacity 1000 - 2500 kg  
 R 10 - R 25 / HD / N / W

Series 1120

### Safety

With four independent braking systems, fail-to-safe dual circuitry and an impressive range of operator protection features, a safe and efficient working environment is assured.

### Performance

Powerful AC traction and lift motors combined with the renowned Linde intelligent controller to deliver seamless, energy efficient performance for optimum productivity. Fixed clear view triplex masts with integrated sideshift as standard ensure smooth, highly efficient storage and retrieval cycles.

### Comfort

A world first sees the operator's work station resiliently mounted to the base chassis isolating the operator from shocks and vibrations. An ergonomic, fully adjustable air suspension seat and integral control console housing the fingertip joystick hydraulic levers together with a compact steering wheel gives unsurpassed levels of operator comfort. The unique Linde rheological electric steering system enables effortless operation and assured manoeuvring and travelling. In this superb, stress-free working environment, the operator is motivated and can fully focus on the task.

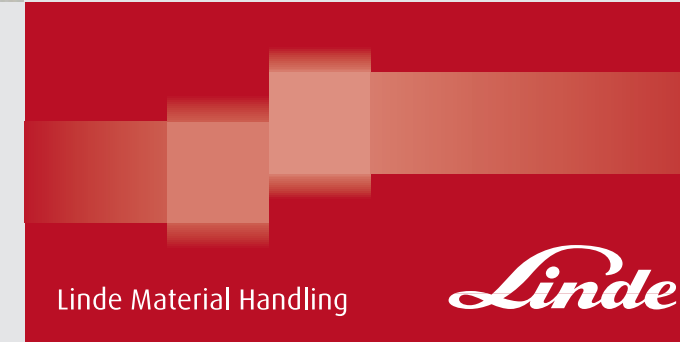

## Features

#### Superb working environment

→ Outstanding comfort and functionality from the unique, resiliently mounted work station with an air suspension comfort seat that is fully adjustable to the operator's personal preferences  
 → Integral, adjustable control console incorporating all operating controls  
 → Linde Load Control: precise, effortless fingertip control of all mast movements  
 → High Vision armoured glass overhead guard top panel available as an option



#### Stability

→ Chassis designed and built for maximum strength and durability  
 → Heavy-duty design and components enhance the inherent low centre of gravity for optimum stability and high residual capacities  
 → Linde Curve Assist for safe cornering

#### Linde twin accelerator pedals

→ Seamless and effortless forward/reverse selection provides outstanding traction control and places minimal demands on operator  
 → His left foot is safely protected within the chassis contours  
 → The operator is able to maintain high levels of efficiency and productivity

#### Manoeuvrability

→ A short wheelbase with compact chassis dimensions and smooth, electric rheological steering ensure easy, efficient manoeuvring and accurate straight line traction performance  
 → Adjustable steering torque to suit operator's personal preferences  
 → Excellent all-round visibility of the load and surrounding environment

#### Linde clear view mast

→ Torsion-resistant fixed clear view triplex mast  
 → Twin cylinder configuration for optimum visibility  
 → Hydraulic hoses reeved through the mast to enhance visibility

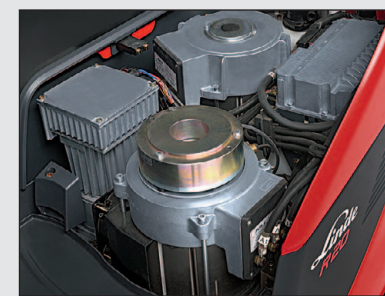
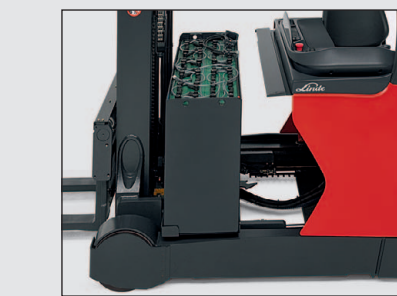

#### Precision

→ Confident, seamless manoeuvring with unique Linde twin accelerator pedals  
 → High precision load handling with Linde Load Control  
 → Highly responsive and progressive electric rheological steering  
 → Digital instrument display for instant readout of truck status  
 → Integral, adjustable operator's control console

#### Batteries

→ Capacities to suit every application: 360 Ah to 930 Ah  
 → Rapid and simple battery change - either lift-out or battery on rollers

#### Servicing

→ Sealed, maintenance-free AC traction, lift and steer motors  
 → Configurable Linde Digital Control system (LDC) incorporates diagnostic technology  
 → Easy service access  
 → Up to 1000 operating hours between services

Linde Material Handling GmbH, Postfach 10 01 36, 63701 Aschaffenburg, Germany  
 Phone +49.6021.99-0, Fax +49.6021.99-1570, www.linde-mh.com, info@linde-mh.com



Subject to modification in the interest of progress. Illustrations and technical details could include options and not binding for actual constructions. All dimensions subject to usual tolerances.

Printed in Germany 145.c.3.10115.indd.k4

# Technical Data according to VDI 2198

Characteristics	Linde															
	R10N	R12N	R14	R14HD	R14N	R16	R16HD	R16N	R20	R20HD	R20N	R20W-1470	R20W-1670	R25		
1.1 Manufacturer	LINDE															
1.2 Model designation	R10N															
1.2a Series	1120-00															
1.3 Power unit	Battery															
1.4 Operation	Seat															
1.5 Load capacity/Load	Q (t)															
1.6 Load centre	c (mm)															
1.8 Axle centre to fork face	x (mm)															
1.9 Wheelbase	y (mm)															
2.1 Service weight	(kg)															
2.3 Axle load without load, front/rear	(kg)															
2.4 Axle load, fork outreached, with load, front/rear	(kg)															
2.5 Axle load, fork retracted, with load, front/rear	(kg)															
3.1 Tyres rubber, SE, pneumatic, polyurethane	Polyurethane															
3.2 Tyre size, front	Ø 360 x 130															
3.3 Tyre size, rear	Ø 285 x 100															
3.5 Wheels, number front/rear (x = driven)	1x / 2															
3.6 Track width, front	b10 (mm)															
3.7 Track width, rear	b11 (mm)															
4.1 Mast/fork carriage tilt, forward/backward	a/b (°)															
4.2 Height of mast, lowered	h1 (mm)															
4.3 Free lift	h2 (mm)															
4.4 Lift	h3 (mm)															
4.5 Height of mast, extended	h4 (mm)															
4.7 Height of overhead guard (cabin)	h6 (mm)															
4.8 Height of seat/stand on platform	h7 (mm)															
4.10 Height of reach legs	h8 (mm)															
4.19 Overall length	l1 (mm)															
4.20 Length to fork face	l2 (mm)															
4.21 Overall width	b1/b2 (mm)															
4.22 Fork dimensions	s/e/l (mm)															
4.23 Fork carriage to ISO 2328, class/type A, B	2A															
4.24 Width of fork carriage	b3 (mm)															
4.25 Fork spread, min/max	b5 (mm)															
4.26 Width between reach legs	b4 (mm)															
4.28 Reach travel	l4 (mm)															
4.31 Ground clearance, below mast	m1 (mm)															
4.32 Ground clearance, centre of wheelbase	m2 (mm)															
4.33 Aisle width with pallet 1000 x 1200 across forks	Ast (mm)															
4.34 Aisle width with pallet 800 x 1200 along forks	Ast (mm)															
4.35 Turning radius	Wa (mm)															
4.37 Length of chassis	l7 (mm)															
5.1 Travel speed, with/without load	(km/h)															
5.2 Lifting speed, with/without load	(m/s)															
5.3 Lowering speed, with/without load	(m/s)															
5.4 Reach speed, with/without load	(m/s)															
5.8 Maximum climbing ability, with/without load	(%)															
5.9 Acceleration time, with/without load	(s)															
5.10 Service brake	hydr./mech.															
6.1 Drive motor, 60 minute rating	(kW)															
6.2 Lift motor, rating at S3 15%	(kW)															
6.3 Battery according to DIN 43531/35/36 A,B,C,no	43 531 / B															
6.4 Battery voltage/rated capacity (Sh)	(V/Ah)															
6.5 Battery weight (± 5%)	(kg)															
6.6 Power consumption according to VDI cycle	(kWh/h)															
8.2 Operating pressure for attachments	(bar)															
8.3 Oil flow for attachments	(l/min)															
8.4 Noise level at operator's ear	(dB(A))															

1) Alternative batteries may alter l1, Ast and service weight.  
 2) With Cabin + 95 mm  
 3) Including a 200 mm (min.) operating aisle clearance.  
 4) Some truck specification require a reach-back restriction. Please note information in Linde  
 World mast table.  
 5) Attention, with cabin increased turning radius (Wa) due to required fender.  
 6) forward; backward  
 7) Depending on performance setting

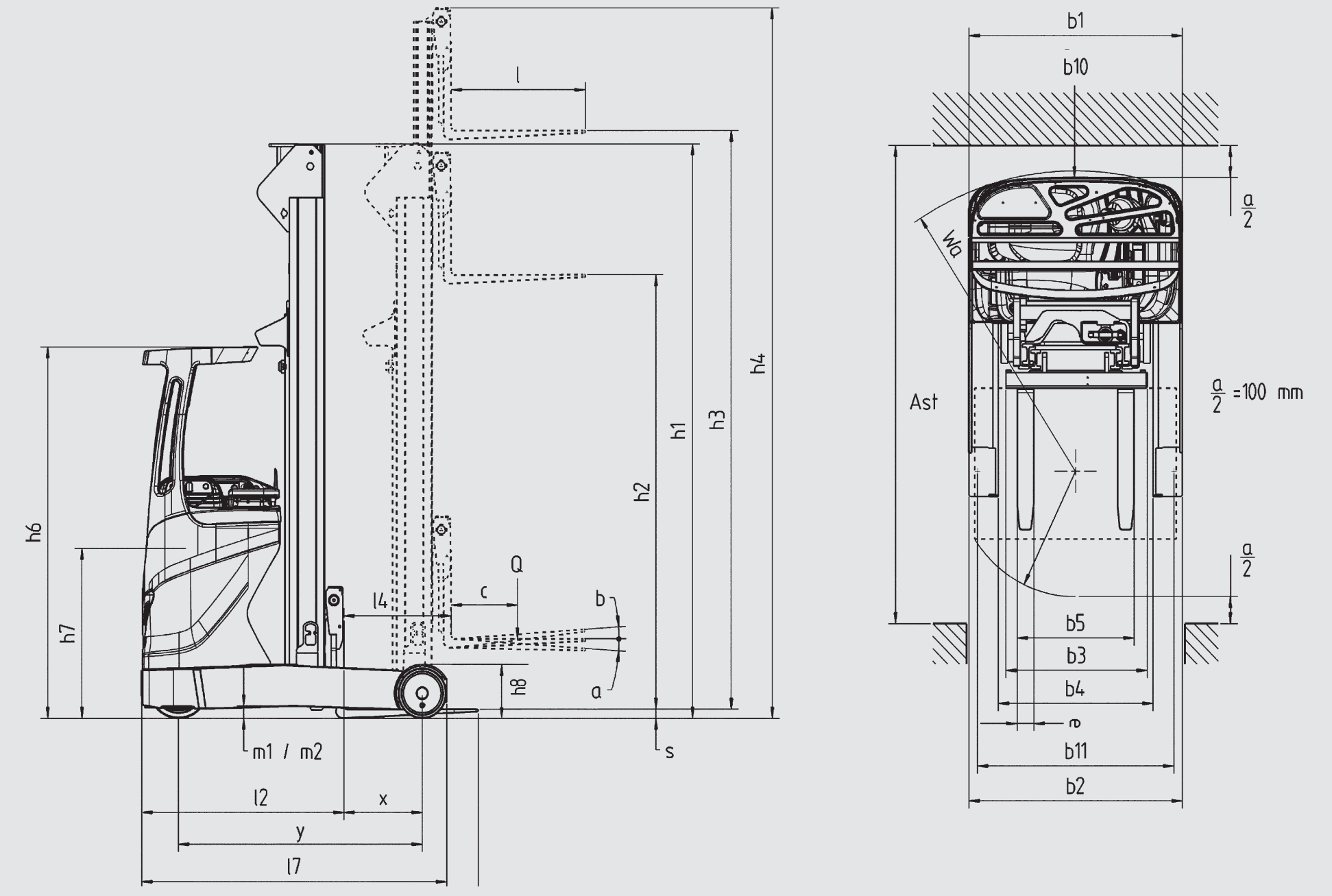

Triplex clearview fixed masts with tilting carriage (2° forward, 4° back) and integrated sideshift (80 mm each side)

R 10 N, R 12 N, R 14 N and R 14																
Lift	<b>h3</b>	4660	5160	5760	6260	6660	6960	7260	7560	7960	8260	8560	-	-	-	-
Free lift	<b>h2</b>	1286	1436	1636	1811	1936	2061	2161	2261	2411	2511	2636	-	-	-	-
Height of mast, lowered	<b>h1</b>	2135	2285	2485	2660	2785	2910	3010	3110	3260	3360	3485	-	-	-	-
Height of mast, extended	<b>h4</b>	5549	6049	6649	7149	7549	7849	8149	8449	8849	9149	9449	-	-	-	-

R 16 N and R 16 N																
Lift	<b>h3</b>	4660	5160	5760	6260	6660	6960	7260	7560	7960	8260	8560	-	-	-	-
Free lift	<b>h2</b>	1286	1436	1636	1811	1936	2061	2161	2261	2411	2511	2636	-	-	-	-
Height of mast, lowered	<b>h1</b>	2135	2285	2485	2660	2785	2910	3010	3110	3260	3360	3485	-	-	-	-
Height of mast, extended	<b>h4</b>	5549	6049	6649	7149	7549	7849	8149	8449	8849	9149	9449	-	-	-	-

The following lifts are available within the parameters indicated for the models shown:

R 14 HD: 4355 - 9455 mm, R 16 HD: 4355 - 11455 mm, R 20: 4355 - 11455 mm, R 20 HD: 4355 - 12955 mm, R 20 N: 4355 - 9455 mm, R 25: 4355 - 7955 mm																
Lift	<b>h3</b>	4355	4655	5155	5755	6355	6655	6955	7255	7555	7955	8255	8555	8955	9155	
Free lift	<b>h2</b>	1001	1101	1251	1451	1651	1751	1851	1951	2051	2201	2301	2401	2526	2601	
Height of mast, lowered	<b>h1</b>	2130	2230	2380	2580	2780	2880	2980	3080	3180	3330	3430	3530	3655	3730	
Height of mast, extended	<b>h4</b>	5101	5401	5901	6501	7101	7401	7701	8001	8301	8701	9001	9301	9701	9901	

R 14 HD: 4355 - 9455 mm, R 16 HD: 4355 - 11455 mm, R 20: 4355 - 11455 mm, R 20 HD: 4355 - 12955 mm, R 20 N: 4355 - 9455 mm, R 25: 4355 - 7955 mm																
Lift	<b>h3</b>	9455	9655	9955	10155	10455	10655	10955	11155	11455	11755	11955	12255	12455	12955	
Free lift	<b>h2</b>	2701	2751	2901	3026	3176	3301	3476	3601	3801	3975	4100	4300	4425	4800	
Height of mast, lowered	<b>h1</b>	3830	3880	4030	4155	4305	4430	4605	4730	4930	5105	5230	5430	5555	5930	
Height of mast, extended	<b>h4</b>	10201	10401	10701	10901	11201	11401	11701	11901	12201	12501	12701	13001	13201	13701	

Alternative lift heights are available on request.  
 Lift height = h3 + s