



EPL1531

Electric Pallet Truck 1.5T

- Improved new plug-in&out Li-Ion battery;
- Smart lithium battery;
- Newly designed handle head;
- Pass market tests of safety and reliability.

EP EQUIPMENT CO.,LTD
www.ep-ep.com



FEATURE

■ Improved new plug-in&out Li-Ion battery

Improved new plug-in&out Li-Ion battery to replace the old one.

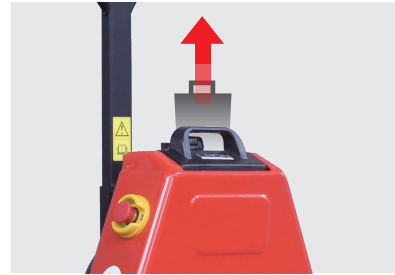

■ Smart Lithium Battery

EPL1531 features a 24V/20Ah li-ion plug&play battery and an external battery as standard to cope with different working shifts need.



■ Newly Designed Handle Head

It is lifted by electricity and lowered manually, there is no need to worry about damaging goods by uncontrollable lowering.



■ Pass Market Tests Of Safety And Reliability

It has 10-year market-tested components.



Electric Pallet Truck 1.5T

EPL1531

Distinguishing mark				
1.1	Manufacturer			EP
1.2	Model designation			EPL1531
1.3	Drive unit			Battery
1.4	Operator type			Pedestrian
1.5	rated capacity	Q	kg	1500
1.6	Load center distance	c	mm	600
1.8	Load distance	x	mm	950(880)
1.9	Wheelbase	y	mm	1190(1120)
Weight				
2.1	Service weight (include battery)		kg	120
2.2	Axle loading, laden driving side/loading side		kg	480/1140
2.3	Axle loading, unladen driving side/loading side		kg	90/30
Types,Chassis				
3.1	Tyre type driving wheels/loading wheels			PU/PU
3.2	Tyre size, driving wheels (diameter×width)		mm	Φ210x70
3.3	Tyre size, loading wheels (diameter×width)		mm	Φ80x60(Φ74x88)
3.4	Tyre size, caster wheels (diameter×width)		mm	/
3.5	Wheels, number driving, caster/loading (x=drive wheels)		mm	1x, 4(1x, 2)
3.6	Track width, front,driving side	b10	mm	/
3.7	Track width,rear,loading side	b11	mm	410/(535)
Dimensions				
4.4	Lift height	h3	mm	115
4.9	Height drawbar in driving position min./max.	h14	mm	750/1190
4.15	Lowered height	h13	mm	80
4.19	Overall length	l1	mm	1540
4.20	Length to face of forks	l2	mm	400
4.21	Overall width	b1	mm	560(685)
4.22	Fork dimensions	s/ e/ l	mm	50x150x1150
4.25	Distance between fork-arms	b5	mm	560(685)
4.32	Ground clearance, center of wheelbase	m2	mm	30
4.34.1	Aisle width for pallets 1000 × 1200 crossways	Ast	mm	2145
4.34.2	Aisle width for pallets 800 × 1200 lengthways	Ast	mm	2050
4.35	Turning radius	Wa	mm	1330
Performance data				
5.1	Travel speed, laden/ unladen	km/ h	km/h	4.5/5
5.2	Lifting speed, laden/ unladen		m/ s	0.017/0.020
5.3	Lowering speed, laden/ unladen		m/ s	0.09/0.06
5.8	Max. gradeability, laden/unladen		%	6\16
5.10	Service brake type			electric
Electric-engine				
6.1	Drive motor rating S2 60 min		kW	0.75
6.2	Lift motor rating at S3 15%		kW	0.7
6.3	The maximum allowed size battery		mm	200x100x350
6.4	Battery voltage/nominal capacity K5		V/Ah	24/20
6.5	Battery weight		kg	7
Addition data				
8.1	Type of drive control			DC
10.5	Steering type			mechanical
10.7	Sound pressure level at the driver's ear		dB (A)	<74

If there are improvements of technical parameters or configurations, no further notice will be given.
The diagram shown may contain non-standard configurations.

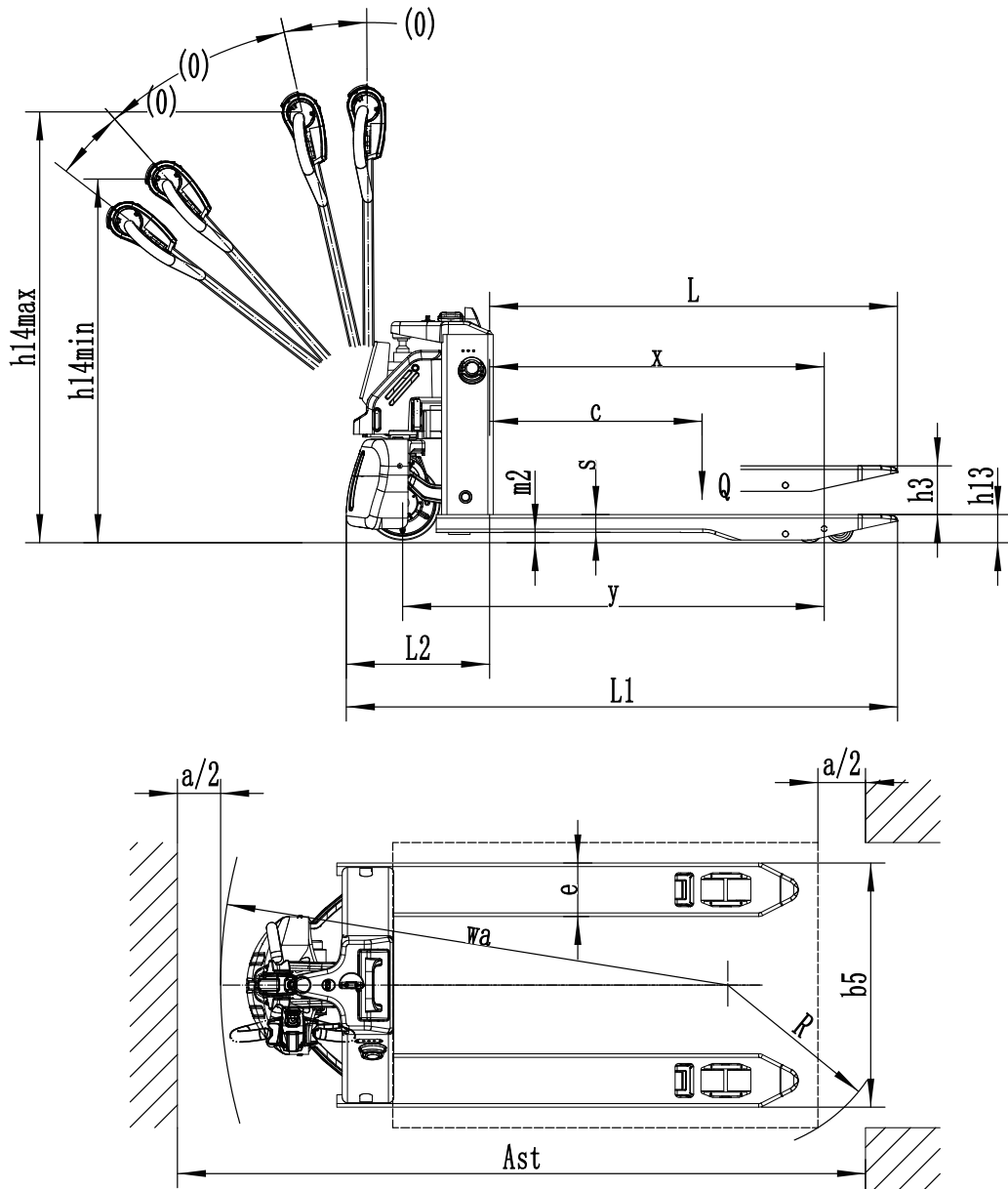

Option:

Optional items		EPL1531
1	Fork length	1150/900/1000/1220/1350/1500
2	Fork width	560/685
8	Double load wheel	•
9	Single load wheel	○
19	Battery capacity	24V/20Ah
25	Vertical handler working	•

Note: • standard ○ option — NA