

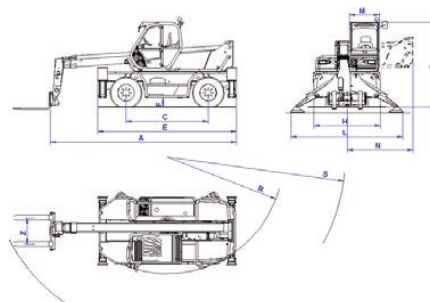

WAGHÄUSEL - HEIDELBERG - MANNHEIM - BENSHEIM - SPEYER

## Merlo Roto 40.18

max. Hubhöhe	17,70 m
max. Ausladung	15,10 m
max. Tragfähigkeit	4.000 kg
Höhe	2,97 m (P)
Länge (einschl. Gabelrücken)	6,02 m (A)
Breite	2,24 m (H)
Eigengewicht	13.100 kg
Abstützbreite	3,75 m (L)
Klappstützen	
Lenkung	Allrad / Vorderrad
	Hundegang
Antrieb	Diesel
Besonderheiten	
	- Fernbedienung (Kranfunktion)
Anbaugeräte	
	- Gabeln 1,20 m
	- Seilwinde bis 4t

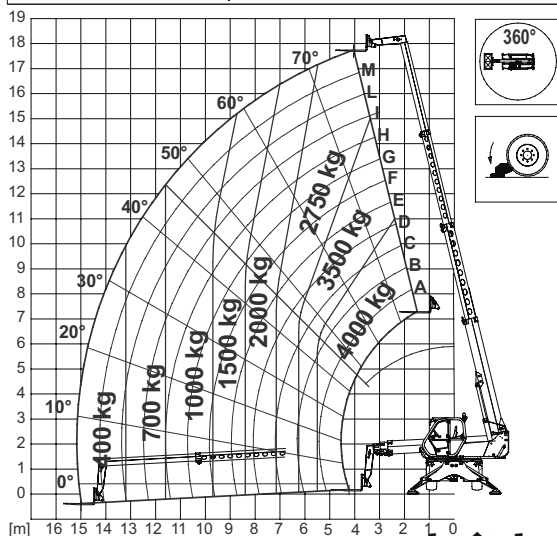

[www.arbeitsbuehnen-hoffmann.de](http://www.arbeitsbuehnen-hoffmann.de)

Arbeitsbuehnen Hoffmann GmbH ♦ Mannheimer Str. 140 a ♦ 68753 Waghäusel

Tel.: 07254 95881-0 / Fax: -88 / [info@arbeitsbuehnen-hoffmann.de](mailto:info@arbeitsbuehnen-hoffmann.de)

# ROTO 40.18 S

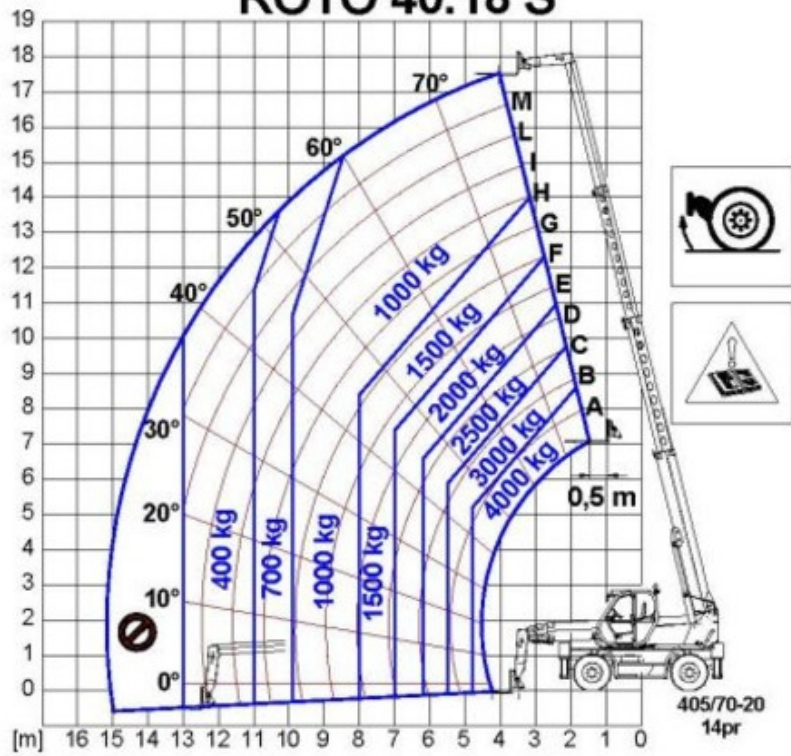

# ROTO 40.18 S

