

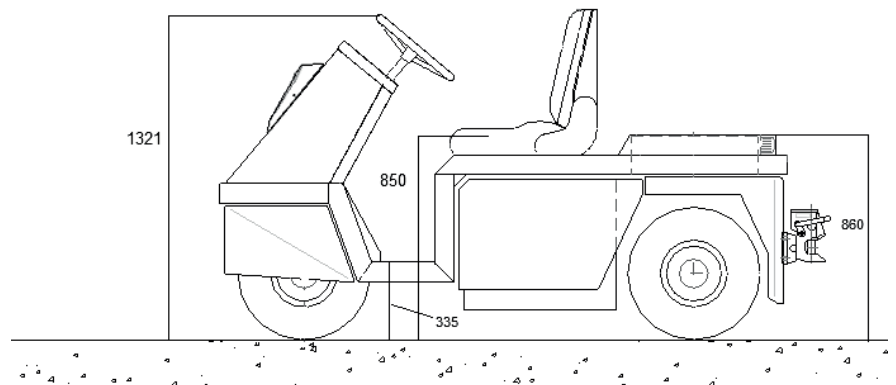

SPIJKSTAAL 310

The electric tricycle tow tractor 310 is unique. It is equipped with a powerful 48 Volt - 10 KW AC motor and is suitable for towing loads up to 10 tons. This tractor performs superbly on slopes. The low centre of gravity makes the tow tractor particularly stable. The ergonomics and the excellent suspension with long springs make this tow tractor very suitable for outdoor use. This tow tractor, with standard horizontal battery replacement system, can be equipped with a two sliding doors cabin that remain within the chassis.





	310	
DRIVE / BATTERY		
Asynchrone AC motor	10	kW
Battery voltage	48	V
Battery capacity	450	Ah
Transmission	1:19	
PERFORMANCE		
Max. speed	17	km/u
Towing capacity	10.000	kg
Max. drawbar pull	8.500	N
WEIGHTS		
Service weight (incl. batt.)	1.550	kg
DIMENSIONS		
Length	2.270	mm
Width	1.020	mm
Height (with cabine)	1.865	mm
Track width rear	887	mm
Wheelbase	1.559	mm
Ground clearance, centre of wheelbase	140	mm
Turning radius	2.240	mm
TYRES / SUSPENSION		
Tyres size, front	6.00*9	
Tyres size, rear	6.00*9	
Suspension front	Helical spring with shock absorber	
Suspension rear	Helical spring with shock absorber	
BRAKES		
Service brake	Hydraulic operated disc brakes	
Parking brake	Mechanical on differential	
OPTIONS E.G.		
Flash light	Cabin	
Various trailer couplings	Bluespot	

Spijkstaal International B.V.
Mandemakerstraat 150-152
3194 DG Hoogvliet
+31 (0)181457030
info@spijkstaal.nl

SPIJKSTAAL.COM