

# Baoli

## EP 16-N01



Baoli

1.1	Manufacturer		KION BAOLI
1.2	Manufacturer's type designation		EP 16-N01
1.3	Drive: electric, diesel, petrol, fuel gas		Electric
1.4	Operator type: hand, pedestrian, standing, seated, order-picker		Pedestrian
1.5	Rated capacity / Rated load	Q (t)	1.6
1.6	Load centre distance	c (mm)	600
1.8	Load distance, centre of drive axle to fork	x (mm)	892
1.9	Wheelbase	y (mm)	1261
2.1	Service weight	Kg	445
2.2	Axle loading, laden front/rear	Kg	715/1330
2.3	Axle loading, unladen front/rear	Kg	345/100
3.1	Tyres: solid rubber, superelastic, pneumatic, polyurethane		PU
3.2	Tyre size, front		Ø 230x70
3.3	Tyre size, rear		Ø 84x84
3.4	Additional wheels (dimensions)		Ø100x40
3.5	Wheels, number front/rear (x = driven wheels)		1x+2/4
3.6	Tread, front	b10 (mm)	510
3.7	Tread, rear	b11 (mm)	367/512
4.4	Lift	h3 (mm)	125
4.9	Height drawbar in driving position min/max	h14 (mm)	820/1335
4.15	Height, lowered	h13 (mm)	85
4.19	Overall length	l1 (mm)	1670
4.20	Length to face of forks	l2 (mm)	520
4.21	Overall width	b1/b2 (mm)	729
4.22	Fork dimensions ISO 2331	s/e/l (mm)	60x173x1150
4.25	Distance between fork-arms	b5 (mm)	540/685
4.32	Ground clearance, centre of wheelbase	m2 (mm)	25
4.34.1	Aisle width for pallets 1000 x 1200 crossways	Ast (mm)	1885
4.34.2	Aisle width for pallets 800 x 1200 lengthways	Ast (mm)	1935
4.35	Turning radius	Wa (mm)	1440
5.1	Travel speed, laden/unladen	km/h	6,0/6,0
5.2	Lift speed, laden/unladen	m/s	0,025/0,035
5.3	Lowering speed, laden/unladen	m/s	0,035/0,030
5.8	Max gradeability, laden/unladen	%	8/15
5.10	Service brake		Electromagnetic
6.1	Drive motor rating S2 60 min	kW	1.3
6.2	Lift motor rating at S3 15%	kW	0.8
6.3	Battery according to DIN 43531/35/36 A, B, C, no		2VBS
6.4	Battery voltage/nominal capacity K5	V/Ah	24/160
6.5	Battery weight	kg	150
6.6	Energy consumption according to VDI cycle	kWh/h	0.44
8.1	Type of drive unit		AC
10.7	Sound pressure level at driver's seat	dB (A)	67

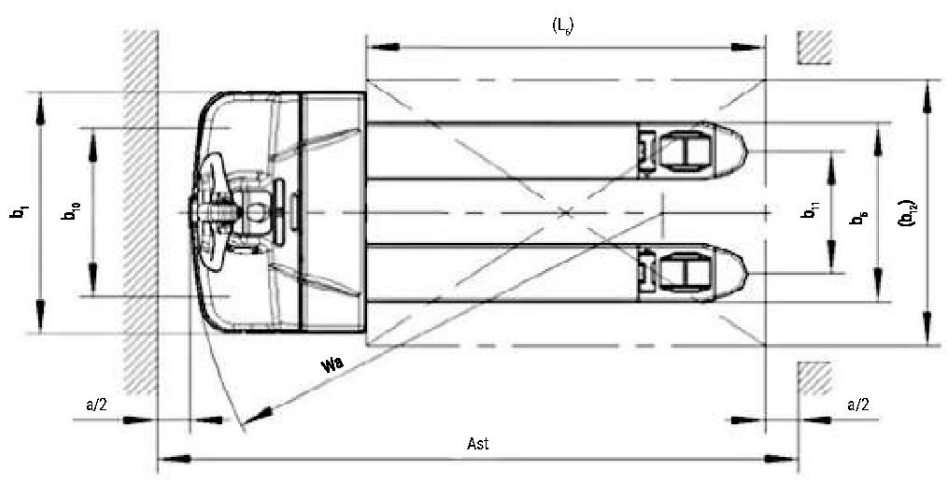
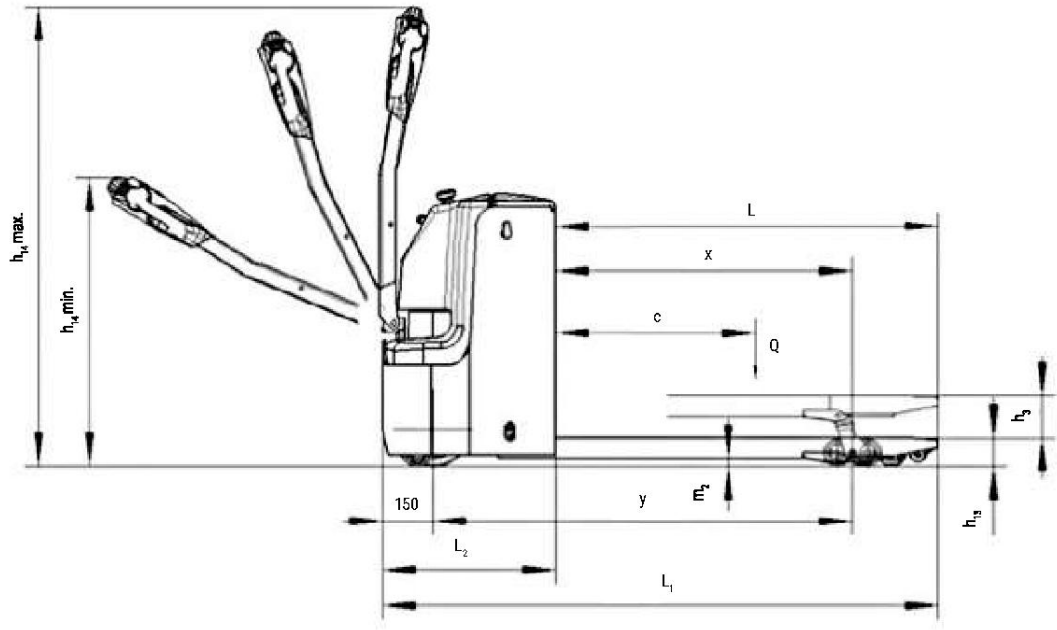

## EP 16-N01 - EP20-N04 - EP 25-N02



The EP 16-N01, EP 20-N04, and EP 25-N02 pallet trucks, with a respective load capacity of 1600, 2000, and 2500 kg, are perfect for loading and unloading vehicles and for any type of medium-intensity handling. High construction quality and excellent technological content make these pallet trucks a real benchmark in their sector. The EP 16-N01, EP 20-N04, and the EP 25-N02 guarantee maximum efficiency and reduced maintenance costs. The EP 16-N01 model has a very compact chassis and is ideal for use in the tightest spaces.

The EP 25-N02 features a longer chassis to guarantee the necessary stability and a battery capacity of 24 V / 350 Ah.

The long tiller arm provides optimal and highly ergonomic control of the vehicle. It requires less operating force and allows the driver to keep an optimal distance from the vehicle.

Top-quality components, robust construction and simplified maintenance make the pallet trucks of this series reliable partners for any kind of use.

### Technology and features

- ✓ AC technology
- ✓ High-quality components
- ✓ Electronics protected against water and dirt
- ✓ Good driving modulation
- ✓ Robust construction
- ✓ Castor wheels for improved truck stability
- ✓ Forks with an overall width of 560 or 685 mm available
- ✓ Single or twin load rollers available
- ✓ Fork length up to 2400 mm (2 pallets)
- ✓ Low-mounted tiller for less manoeuvring effort.

